

GATEWAY GW1000

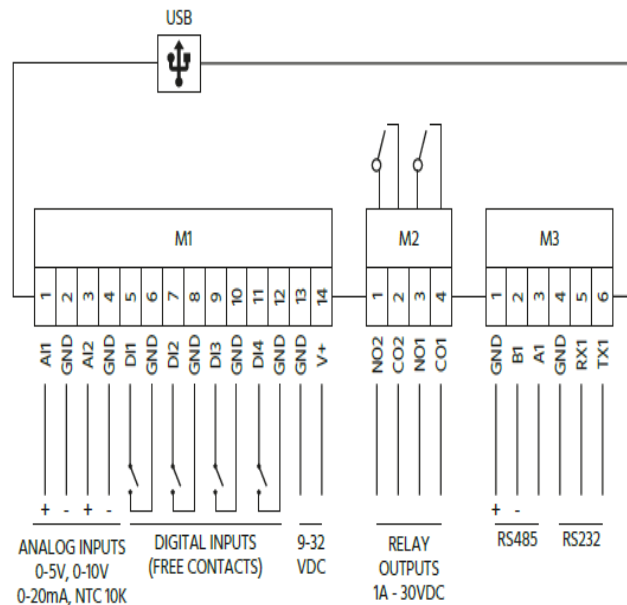

- Local gateway with WI-FI connection to a cloud server.
- Crypted communication between installations and cloud server (secure communication).
- Access anytime to read all actual fan parameters.
- User levels access (read – read/write) .
- Access anytime to any fan to modify some parameters.
- Access to all data registered by the gateway and possibility to download them (EXCEL,CSV,PDF).
- Fixed annual subscription regardless of the number of connected devices.
- 2 Relay outputs for auxiliary systems (showers, etc.).
- Alarm notifications through e-mail .
- Additional data Collection from external sensors (furthermore to the motor's sensors) .
- Unlimited number of fans/sensors connected at the same network.
- Synoptic diagram to see the installation situation and performance at a glance.
- 2 non isolated analog inputs.
- 4 digital inputs.
- 24V Power supply.
- DIN rail mounting.
- Included Switchboard IP65 with circuit breaker, power supply, and local temperature probe

SEDE LEGALE / LEGAL ENTITY

Via Luigi Albertini, 36 D/5 | 60131 Ancona (AN)
Tel./Phone +39 071 2865015
P. IVA / VAT: IT 02687550422 | Sdi T04ZHR3



SEDE OPERATIVA / PRODUCTION PLANT

Via dell'Artigianato, 3 | 29012 Caorso (PC)
Tel./Phone +39 0523 821223
Mail: info@evelsrl.it